



System 5000

5021D-IS Wideband Delay Line System with Internal Spool Installation Manual Revision B

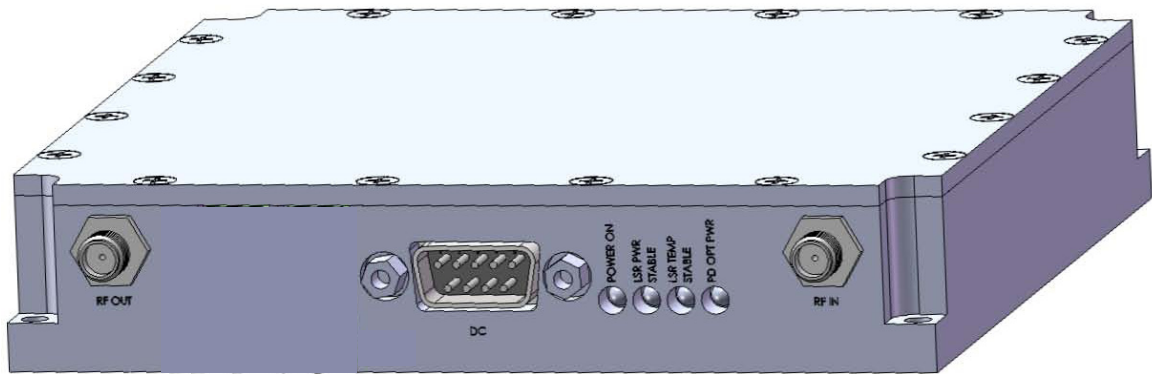

Table of Contents

General..... **3**

 Interface..... 4

Installation..... **5**

Operation..... **5**

 Delay System..... 5

 LED Indicator Tables & Diagram..... 6

Remote Monitoring..... **6**

 Discrete..... 6

Specifications **7**

Ordering Information **8**

Optics Handling & Safety **9**

Warranty **10**

EMCORE Corporation is a leading provider of advanced mixed-signal products that serve the aerospace & defense and broadband communications markets. Our best-in-class components and systems support a broad array of applications including navigation and inertial sensing, defense optoelectronics, broadband transport, 5G wireless infrastructure, optical sensing, and cloud data centers. We leverage industry-leading Quartz MEMS, Lithium Niobate and Indium Phosphide chip-level technology to deliver state-of-the-art component and system-level products across our end-market applications.

EMCORE’s broadband solutions include optical components and subsystems for fiber optic ground station links for global satellite communications, fiber-to-the-premise, cable television, high speed data and telecommunication networks.



2015 Chestnut Street Alhambra, California 91803, USA
 (626) 293-3400 Fax: (626) 293-3428 www.emcore.com

General

- Stand-alone system ideal for multi-platform enclosures.
- Fully integrated laser and photodiode
- Internal delay spool (250 nanosecond max)
- Bandwidth from 50 MHz to 18 GHz
- 50 Ohm
- Fixed RF gain
- Multiple monitoring options provide for panel LED & discrete signal monitoring

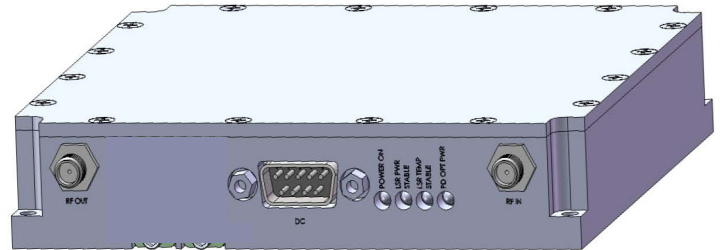

System 5000 Wideband Microwave Transceiver fiber optic intra-facility links are a high-performance, cost-effective alternative to coaxial cable. They provide much longer transmission distances than copper cables, which simplify network design, ease installation and even enhance immunity from EMI, RFI and lightning. These transmitters and receivers take the best RF design features of EMCORE's extensive families of products and combine them into a compact package compatible with the 10901G Power Supply.

The System 5000 Wideband Microwave Transceiver family's wide range of RF with a single chassis. The final result is a system that can be factory or user custom configured to meet a wide range of fiber transport applications.

Interface

Figure 01

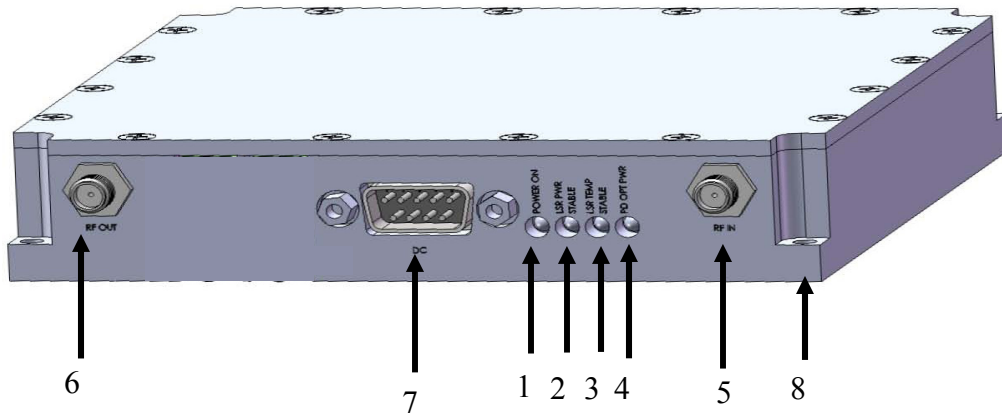

1. **Power** This LED illuminated indicates when DC power is present and off when there is no DC power.
2. **Laser Power** The LED illuminated indicates the laser is operating 10% above its set-point.
3. **Laser Temp** This LED illuminated indicates the laser is operating within $\pm 2\%$ of its set-point.
4. **Photodiode Optical Power** The LED illuminated indicates the photodiode is receiving optical power greater the -12 dBm.
5. RF Input
6. RF output
7. DC Power
8. Mounting

Installation

Module Installation

- Apply DC power
- Verify that the Power On, Laser Power, Laser Temp and Optical Power LEDs are illuminated.
- Connect RF input and output signal cables.

DC Interface (Table 01)

J1 Pin	Function
1	+15 VDC
2	+5 VDC
3	Not Use
4	Ground
5	Ground
6	Photodiode Current Monitor
7	Alarm Common
8	Laser Current Monitor
9	Alarm

Operation

Delay System

Every step has been taken to ensure simple hands-free operation. This will provide the lowest possible distortion.

After ensuring that the 5021 equipment is securely mounted, ensure that the LED's listed below are illuminated.

Power - Green:	DC power is applied to the transmitter.
Laser Power - Green:	Laser Power is operating 10% above set point.
Laser Temp - Green:	Laser Temperature is operating $\pm 2\%$ from set point.
Optical Power - Green:	Optical power greater than -12 dBm is received.

Verify that the delay line has the specified delay and insertion loss, refer to the supplied test data sheet.

LED Indicator Tables & Diagram

TX Status LED (Table 02)

LED, Alarm	LED, Good	LED	Notes, Good State
Off	Green	Power	DC Power, present
Off	Green	Laser Power	Laser Power, 10% above set point
Off	Green	Laser Temp	Laser Temp, ±2% above set point
Off	Green	Optical Power	Optical power > -12 dBm

System 5000 Wideband Fiberoptic Delay Line

5021 Delay Line

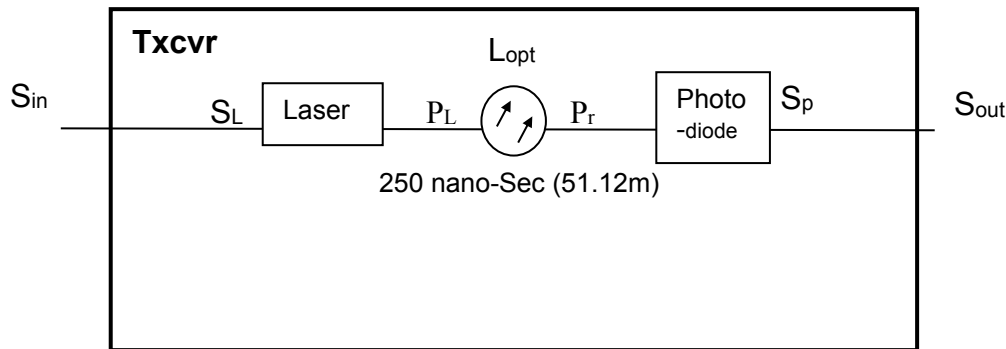

Remote Monitoring

Discrete

The System 5000 System is designed to provide remote status. Use of this feature requires the use of a network management system that can accept discrete inputs.

▪ 5021 – Delay Line

Monitored Values

Laser Current	1V/100mA
Photodiode Current	1V/1mA
Summary Alarm	Dry Contact – Sums the Laser Temp, Laser Power and Photodiode Low Optical Power alarms

Specifications

5021

RF Frequency	50 MHz – 18 GHz	RF Flatness	5 dB max (pp)
RF Flatness	7 dB max (pp)	RF Return loss	>-4 dB
RF Return loss	>-4 dB	Fiber Delay	250 nano-sec max
Carrier/Noise ratio	115 dB/Hz(*)	Transmit Gain (TG)	-24 dB
Carrier/Intermod Ratio	>55 dB(*)	Receive Gain (RG)	-11 dB
Spur Free Dyn Range*	98 dBHz ^{2/3}	System Gain (SG)	TG + RG +2*Optical Loss
* (Two tones peaked)			
Photodiode Current	10 mA max		
3 rd order intercept,	>20 dBm		

System 5000 General

Certifications	CE,CSA,FCC,
Operating Temperature	-40 to 60°C
Storage Temperature	-40 to 85°C
Humidity, non-condensing	5 to 95%
Dimensions (HxWxD)	1.00" x 5.00" x 5.00"
Weight, Typical	1.5 lbs

Ordering Information

Model Number

Each EMCOREEMCORE product is assigned a unique model number and serial number, which appears on the label of the unit. Model numbers for this series have the form **5021D-X11-ZZZZZZ** here; 'X' is a one letter designation for the appropriate frequency of the unit, 'YY' is a two letter designation the unit overall height and max delay option 11 – 1 inch, 250 nanosecond max Delay Line and "ZZZZZZ" is a six letter designation specifying the Delay time in microseconds, X (hundreds) X (tens) X (ones) X (tenths) X (hundredths) X (thousandths). For the 5021D-(X)11 family only the X (tenths) X (hundredths) X (thousandths) places are used the X (hundreds) X (tens) X (ones) are always zero .

Model Number	Description
---------------------	--------------------

Delay Line System

5021D-A11-XXXXXX	Delay, 3 GHz, 50 Ohm SMA, 1310nm, Delay Time to 250 nano-sec max
5021D-B11-XXXXXX	Delay, 7 GHz, 50 Ohm SMA, 1310nm, Delay Time to 250 nano-sec max
5021D-C11-XXXXXX	Delay, 12 GHz, 50 Ohm SMA, 1310nm, Delay Time to 250 nano-sec max
5021D-D11-XXXXXX	Delay, 18 GHz, 50 Ohm SMA, 1310nm, Delay Time to 250 nano-sec max

Power Supplies

10901G-NA	Power Supply for 10990A North America AC cord
10901G-UK	Power Supply for 10990A United Kingdom AC cord
10901G-EU	Power Supply for 10990A European AC cord
8218-003	DC power cable for use with the 10901G Power Supply
8218-002	DC power cable for use with the Laboratory Power Supply

Optics Handling & Safety

Working with fiber optic cables and interfaces require a clean dust free environment. The optical power is confined in the optical core only a few microns in diameter. Small particles of dust can block the proper transfer of light through the connectors. It is therefore important to keep connectors as clean as possible, and when in doubt of the cleanliness of a connector, clean it prior to inserting into a transmitter or receiver receptacle.

A number of events can damage fiber optic connectors. Unprotected connector ends can experience damage by impact, airborne dust particles, or excess humidity or moisture. Never touch the fiber end face of the connector.

When cleaning fiber optic connectors use only Industrial grade 99% pure isopropyl alcohol, lens-grade, lint-free tissue, and optionally canned dry air. Alternatively, there are a number of simple, effective products that are specifically designed for cleaning fiber optic connectors.

Never look onto an illuminated fiber end.

Disclaimer

Every attempt has been made to make this material complete, accurate and up-to-date. Users are cautioned that EMCORE reserves the right to make changes without notice and shall not be held responsible for any damages, including consequential, caused by reliance on the material presented, including, but not limited to, typographical, arithmetical, or listing errors.

WARNINGS, CAUTIONS, LIABILITY, WARRANTY AND GENERAL NOTES

Safety Considerations

When installing or using this product, observe all safety precautions during handling and operation. Failure to comply with the following general safety precautions and with specific precautions described elsewhere in this manual violates the safety standards of the design, manufacture, and intended use of this product. EMCORE assumes no liability for the customer's failure to comply with these precautions.



The fiberoptic laser transmitter used in EMCORE's System 5000 link contains a class IIIb laser product as defined by the U.S. Department of Health and Human Services, Public Health Service, Food and Drug Administration. This laser product complies with 21 CFR, Chapter I, Subchapter J of the DHEW standards under the Radiation Control for Health and Safety Act of 1968.

The laser operates at nominally 1310 nm with less than 30 mW optical output. The typical optical output for this product is less than 10 mW. The protective laser plug-in module housing prevents a user from being exposed to hazardous optical output levels. Since there is no human access to the laser output during system operation, no special operator precautions are necessary when fiber is connected to the transmitter and receiver. During installation, service, or maintenance, the service technician is warned to not look directly into the end of the fiber connector or the fiber. The light emitted from the fiberoptic connector or any fiber connected to the transmitter is invisible and may be harmful to the human eye. Use either an infrared fluorescent screen or an optical power meter for optical output verification. All handling precautions as outlined by Federal agencies or other authorities of class IIIb lasers must be observed.

Do not attempt to modify or to service the laser diode module. Return it to EMCORE for service and repair. Contact the EMCORE Customer Service Department for a return authorization and further instructions.

Electrostatic Sensitivity

Observe electrostatic precautionary procedures. Semiconductor laser transmitters and receivers provide highly reliable performance when operated in conformity with their intended design. However, a semiconductor laser may be damaged by an electrostatic charge inadvertently imposed by careless handling.

Static electricity can be conducted to the laser chip from the center pin of the RF input connector, and through the DC connector pins. When unpacking and otherwise handling the transmitter, follow ESD precautionary procedures including use of grounded wrist straps, grounded workbench surfaces, and grounded floor mats.

Exposure to electrostatic charge is greatly reduced after the transmitter or receiver has been installed in an operational circuit.

Service

Do not attempt to modify or service any part of the system other than in accordance with procedures outlined in this Operation Manual. If the system does not meet its warranted specifications, or if a problem is encountered that requires service, return the apparently faulty plug-in or assembly to EMCORE for evaluation in accordance with EMCORE's warranty policy.

When returning a plug-in or assembly for service, include the following information: Owner, Model Number, Serial Number, Return Authorization Number (obtained in advance from EMCORE's Customer Service Dept.), service required and/or description of the problem encountered.

Warranty

EMCORE warrants to the original purchaser all standard products sold by EMCORE to be free of defects in material and workmanship for one (1) year from date of shipment from EMCORE. During the warranty period, EMCORE's obligation, at our option, is limited to repair or replacement of any product that EMCORE proves to be defective. This warranty does not apply to any product that has been subject to alteration, abuse, improper installation or application, accident, electrical or environmental over-stress, negligence in use, storage, transportation, or handling.

This warranty is the only warranty made by EMCORE and is in lieu of all other warranties, expressed or implied, except as to title, and can be amended only by a written instrument signed by an officer of EMCORE. EMCORE sales agents or representatives are not authorized to make commitments on warranty returns.

Limitations of Liabilities

EMCORE's liability on any claim of any kind, including negligence, for any loss or damage arising from, connected with, or resulting from the purchase order, contract, or quotation, or from the performance or breach thereof, or from the design, manufacture, sale, delivery, installation, inspection, operation or use of any equipment covered by or furnished under this contract, shall in no case exceed the purchase price of the device which gives rise to the claim.

EXCEPT AS EXPRESSLY PROVIDED HEREIN, EMCORE MAKES NO WARRANTY OF ANY KIND, EXPRESSED OR IMPLIED, WITH RESPECT TO ANY GOODS, PARTS AND SERVICES PROVIDED IN CONNECTION WITH THIS AGREEMENT INCLUDING, BUT NOT LIMITED TO, THE IMPLIED WARRANTIES OF MERCHANTABILITY AND FITNESS FOR A PARTICULAR PURPOSE. EMCORE SHALL NOT BE LIABLE FOR ANY OTHER DAMAGE INCLUDING, BUT NOT LIMITED TO, INDIRECT,

SPECIAL OR CONSEQUENTIAL DAMAGES ARISING OUT OF OR IN CONNECTION WITH FURNISHING OF GOODS, PARTS AND SERVICE HEREUNDER, OR THE PERFORMANCE, USE OF, OR INABILITY TO USE THE GOODS, PARTS AND SERVICE.

EMCORE will not be responsible for loss of output or reduced output of opto-electronic devices if the customer performs chip mounting, ribbon bonding, wire bonding, fiber coupling, fiber connectorization, or similar operations. These processes are critical and may damage the device or may affect the device's output or the fiber output.

EMCORE test reports or data indicating mean-time-to-failure, mean-time-between-failure, or other reliability data are design guides and are not intended to imply that individual products or samples of products will achieve the same results. These numbers are to be used as management and engineering tools, and are not necessarily indicative of expected field operation. These numbers assume a mature design, good parts, and no degradation of reliability due to manufacturing procedures and processes.

EMCORE is not liable for normal laser output degradation or fiber coupling efficiency degradation over the life of the device.

Every attempt has been made to make this material as complete and accurate and up to date. Users are cautioned that EMCORE reserves the right to make changes without notice and shall not be held responsible for any damages, including consequential, caused by reliance on the material presented, including, but not limited to, typographical, arithmetical, or listing errors.

© Copyright 2020 EMCORE Corporation