



## Applications

- CATV Systems
- Long Distance RF/Microwave Fiber Optic Communication Links
- Sensing and Control Systems
- High-Performance Supertrunking Links
- Redundant Ring Architectures
- FTTx Networks

## Features

- Full Function Fiber Optic Amplifier Ready for Integration
- Wavelength Range: 1530 nm to 1562 nm
- Low Noise Figure (Typ < 5.0 dB)
- Pin: -10 dBm to +12 dBm
- Pout: +14 dBm to +24.5 dBm
- RS-232 Monitor and Control Interface
- Low Electrical Power Consumption
- Input / Output Isolation > 35 dB / 35 dB
- Polarization Dependent Gain (PDG) < 0.5 dB
- Polarization Mode Dispersion (PMD) < 0.5 ps
- Output Residual Pump Power < -30dB (in reference to the output signal power)
- Input & Output Return Losses < -40 dB
- Polarization Dependent Loss < 0.3 dB

The EMCORE MAFA 5000 Series Micro Erbium Doped Fiber Amplifier ( $\mu$ EDFA) gain block module is an ideal building block for OEM systems integration where there is a requirement to amplify a 1550 nm signal for a broad range of applications including CATV systems, RF/microwave fiber optic links, sensing and control systems, and more. The family of MAFA 5000 EDFA gain blocks is designed to meet the most demanding noise performance requirements of fiber optic communications and control systems, and perform all the functions required of an optical amplifier for system integration.

MAFA 5000 series EDFA gain blocks provide input and output optical isolation for stable, low noise operation. The input and output optical signals are detected for monitoring and control. The input optical signal is amplified with active gain control for a constant output power level or with active output power control for constant gain mode operation.

The MAFA 5000 series EDFA gain blocks also provide monitors and associated alarms for all critical operating parameters. The optical output of the MAFA 5000 series EDFA gain blocks can be split into multiple ports (2, 3 or 4) by an optional internal splitter.

The compact mechanical footprint of the MAFA 5000 allows use of this unit in constrained space environments and high-density applications.

## Optical/Electrical Characteristics <sup>Note 1</sup>

Property	Unit	Limit	Models						Comments Other power levels are possible
			14	17	20	22	23	24	
Operating Input Power	Pin (dBm)	Max	12	12	12	12	12	12	Typical (may vary for some models)
Operating Input Power	Pin (dBm)	Min	-10	-10	-10	-10	-10	-10	Typical (may vary for some models)
Total Output Power	Po (dBm)	Nominal	14 +/- .25	17 +/- .25	20 +/- .25	22 +/- .25	23 +/- .25	24.5 +/- .25	Before Splitter (if installed) Note 2
Noise Figure	NF (dB)	Typ	≤ 5.0 dB	≤ 5.0 dB	≤ 5.0 dB	≤ 5.0 dB	≤ 5.0 dB	≤ 5.0 dB	Note 3
Dynamic Gain Flatness	ΔGd (dB)	Max	+/-2.0	+/-2.0	+/-2.5	+/-2.5	+/-2.5	+/- 8.0	Note 4
Output Power Stability	(dB)	Max	+/- 0.2	+/- 0.2	+/- 0.2	+/- 0.2	+/- 0.2	+/- 0.2	Note 5
Power Consumption (Steady state)	Psys(W)	Max	3	5.5	8	9	11	13	Note 6

### Notes:

- 1) Unless stated otherwise, all specifications apply over the full operating temperature and humidity ranges
- 2) Measurement variations
- 3) Measured @ 25°C, Pin ≈ 0 dBm. λ ≈ 1555 nm
- 4) Measured by combining a small-probe signal (Pin – 20 dB) with the signal (Pin) that sets the EDFA to defined saturation level of Pout. 0 dBm ≤ Pin ≤ 6 dBm (Please contact EMCORE for details, also See "Fiber Optic Test and Measurement" HP, Dennis Derickson, Editor, ISBN 0-13-534330-5, 1998, page 54)
- 5) Over polarization and temperature
- 6) Max - power consumption @ -20°C or +70°C of case temperatures

## General and Mechanical Specifications

Property	Requirement	Comments
Operating Wavelength	1530nm ~ 1562nm	Standard
Operating Case Temperature	0°C to 65°C	Standard*
Storage Temperature	-40°C to 85°C	Standard
Operating Humidity	up to 95%	Non-condensing
Voltage Supply Range	+5VDC	All versions
Optical Connectors	SC, FC, E2000, LC	User Specified
Dimensions (mm)	70 x 90 x 15	All versions

\* Extended temperature range of -20°C to +70°C is also possible

## Outline Drawing (dimensions in mm)

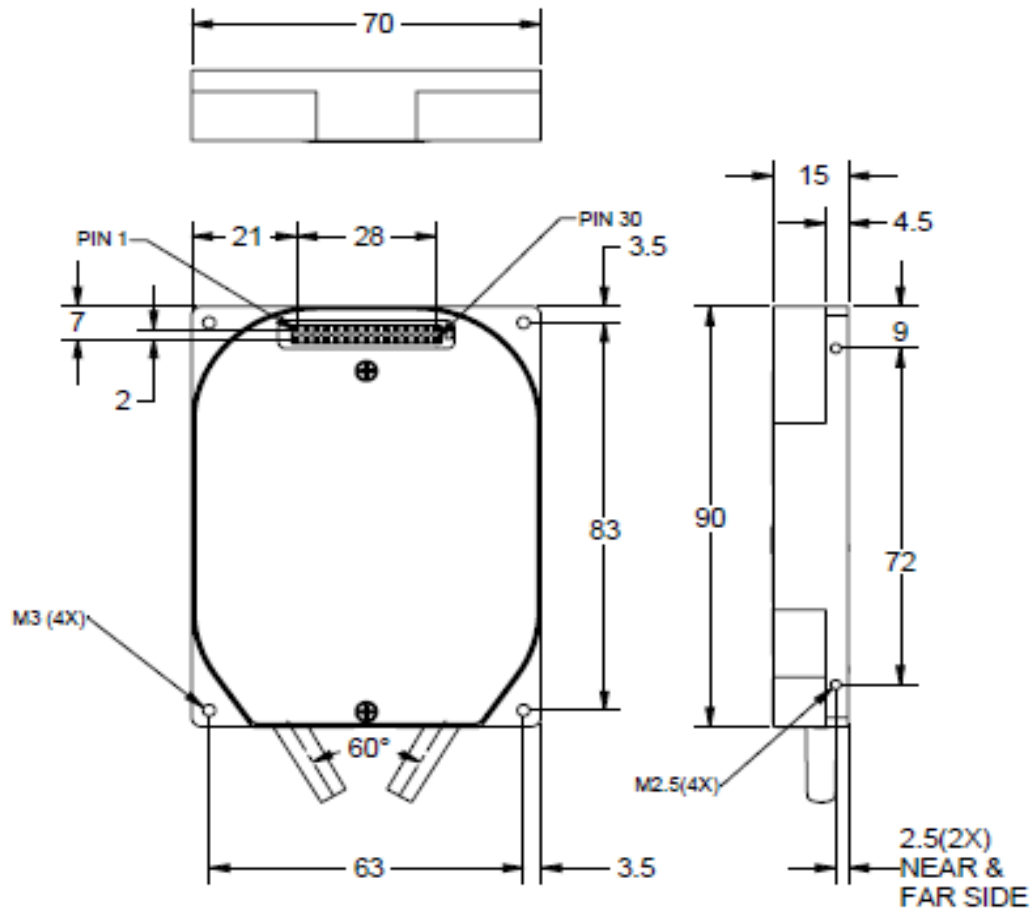

## Compliance and Reliability Information

Class 3B Laser Safety

221,000 hours MTBF at 50°C per Telcordia SR-332, Issue 2

## Electrical Connector Pinout

PIN #	Designation	PIN #	Designation
1	5VDC	16	NC
2	+5VDC	17	Pump_Temp_Alarm (TTL active high)
3	+5VDC	18	Pump_Bias_Alarm (TTL active high)
4	+5VDC	19	Loss_Input_Power (TTL active high)
5	GND	20	Loss_Output_Power (TTL active high)
6	GND	21	GND
7	RS232_Rx	22	GND
8	RS232_Tx	23	Input Power Mon
9	GND	24	Output Power Mon
10	GND	25	GND
11	NC	26	GND
12	EDFA_Reset (TTL active high)	27	RxD
13	EDFA_Disable (TTL active high)	28	TxD
14	Pout_Mute (TTL active high)	29	+5VDC
15	EDFA_Temp_Alarm (TTL active high)	30	+5VDC

\* - SAMTEC, TMM-115-01-L-D

## Ordering Information

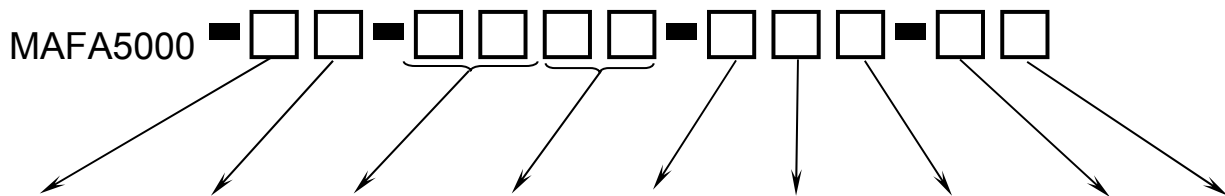

Logo & Customer Specifics	Temperature Option	Output Power Per Port, dBm	Number of Output Ports	Input Connector Type	Output Connectors Type	Required Power Supply	Future Use	Future Use
0 = Emcore Logo	S = Standard	08 = 8	01 = 1 port	1 = SC/APC	1 = SC / APC	1 = +5VDC	0 = NA	0 = NA
		11 = 11		2 = FC/APC	2 = FC / APC			
	E = Extended	14 = 14	02 = 2 ports	3 = E2000 / APC	3 = E2000 / APC			
		17 = 17		4 = LC / APC	4 = LC / APC			
		20 = 20	03 = 3 ports					
		21 = 21						
		22 = 22	04 = 4 ports					
		23 = 23						
		24 = 24						

### Example:

MAFA5000-0S-1401-111-00: MAFA5000 gain block, with Emcore logo, standard temperature range, 14 dBm per port, 1 output port, SC/APC connector on input, SC/APC connector on output, +5VDC power supply required

## Laser Safety Information

This component product classified as a Class 3B laser product based on the maximum optical output power defined below.

Wavelength = 1530 nm ~ 1562 nm (dependent on input source)

Maximum Output Power < 0.3 W (single output, 24.5 dBm model)

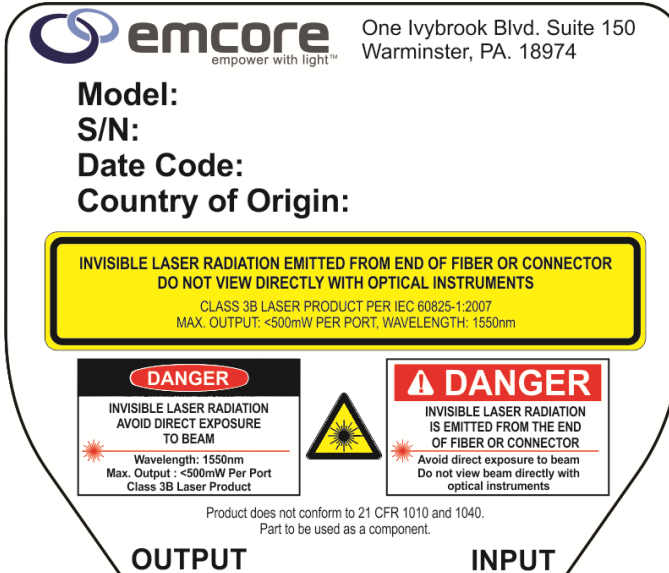

**emcore** empower with light™ One Ivybrook Blvd. Suite 150  
Warminster, PA. 18974

**Model:**  
**S/N:**  
**Date Code:**  
**Country of Origin:**

**INVISIBLE LASER RADIATION EMITTED FROM END OF FIBER OR CONNECTOR  
DO NOT VIEW DIRECTLY WITH OPTICAL INSTRUMENTS**  
CLASS 3B LASER PRODUCT PER IEC 60825-1:2007  
MAX. OUTPUT: <500mW PER PORT, WAVELENGTH: 1550nm

**DANGER**  
INVISIBLE LASER RADIATION  
AVOID DIRECT EXPOSURE  
TO BEAM  
Wavelength: 1550nm  
Max. Output : <500mW Per Port  
Class 3B Laser Product



**DANGER**  
INVISIBLE LASER RADIATION  
IS EMITTED FROM THE END  
OF FIBER OR CONNECTOR  
Avoid direct exposure to beam  
Do not view beam directly with  
optical instruments

Product does not conform to 21 CFR 1010 and 1040.  
Part to be used as a component.

**OUTPUT** **INPUT**