



Applications

- Video Signal Distribution in HFC and FTTx nodes
- Video Overlay in Passive Optical Networks (PON).

Features

- 5 Wide 40 MHz – 1200 MHz Bandwidth Supports as Many as 110 CATV Analog Channels or a Combination of Analog and Digital Channels Including HDTV Broadcast.
- Excellent RF Frequency and Distortion Characteristics for High Linearity.
- Low Noise (3.9 pA/√Hz typ.) Low Power Dissipation (0.75 W max.) as well as High RF Output.
- RoHS Compliant
- Internal Proprietary Impedance Match Circuitry (75Ω)
- Robust Small Package with Singlemode Fiber Pigtail and Connector Options
- Wide Operating Case Temp Range, -30° to + 85°C

The 7840A DOCSIS 3.1 Low Noise CATV Optical Receiver is a singlemode fiber pigtailed module featuring a low-noise, impedance-matched broadband photodiode and RF amplification.

The device receives optical analog and/or digital signals for a range of video broadcast options, and delivers the corresponding RF electrical output. The wide bandwidth supports the delivery of up to 110 CATV analog signals or a combination of analog and digital channels (80/30 for example), including HDTV broadcast.

The 7840A DOCSIS 3.1 exhibits excellent distortion performance with values well above standards over the entire bandwidth and case temperature specifications (40 MHz – 1200 MHz, -30 °C to +85 °C).

Moreover, the proprietary impedance-match circuitry between the photodetector and RF amplification stages resolves a number of OEM design obstacles with very low noise performance value, typically less than 4.5 pA/√Hz.

The 7840A DOCSIS 3.1 Low Noise CATV optical receiver can be used in both 1310 nm and 1550 nm applications being useful at different points of a given network.

The 7840A DOCSIS 3.1 is compliant with all criteria of the Restriction of the Use of Hazardous Substances in Electrical and Electronic Equipment (RoHS) guidelines 2002/95/EC.

Performance Highlights

Parameter	Limits
Frequency Range	40 – 1200 MHz
CTB (79ch NTSC)	-80 dBc (typ)
CSO (79ch NTSC)	-68 dBc (typ)
Optical Input Power	Up to +3 dBm
Wavelength	1260 – 1620 nm
Power Consumption	0.85 W



Absolute Maximum Ratings

Stresses in excess of the absolute maximum ratings can cause permanent damage to the device. These are absolute stress ratings only. Functional operation of the device is not implied at these or any other conditions in excess of those given in the operational sections of the data sheet. Exposure to absolute maximum ratings for extended periods can adversely affect device reliability.

Parameter	Symbol	Min	Max	Unit
Operating Case Temperature Range	T_{CASE}	-30	85	°C
Storage Temperature Range	T_{stg}	-40	85	°C
Humidity at 85 °C	RH	--	85	%

Note: For all tables, typical values are performed at 25°C; min and max values are performance vs. temperature.

Electrical/Optical Characteristics

Parameter	Symbol	Min	Typ	Max	Unit
Optical Power	P_{IN}	--	--	+3	dBm
Optical Return Loss	RL_{OPT}	40	--	--	dB
DC Power					
+5V Amp Bias, (Pin 2)	I_{CCA}	--	--	160	mA
+12V PD Bias, (Pin 6)	I_{CCP}	--	--	3	mA
Wavelength	λ	1260	1310/1550	1620	nm
Responsivity	--	--	>0.85 at 1310 nm >0.95 at 1550 nm	--	mA/mW mA/mW
PDI Monitor Voltage	V_{MON}	--	1.0	--	V/mA
Dissipation	P_{DISS}	--	--	0.85	W

RF Characteristic

Parameter	Symbol	Min	Typ	Max	Unit
Frequency Response	BW	5	--	1200	MHz
Gain (Ref @ 40MHz)	G	18	--	22	dB
Gain Stability (-30°C to + 85°C)	G_{ST}	-0.5	--	+0.5	dB
Ripple (40 MHz – 1200 MHz)	--	--	1	1.2	dBpk-pk
Gain Tilt	--	--	1	2	dB
RF Output Level ⁽²⁾	RF_{OUT}	22	--	24	dBmV/ch
Output Return Loss (40 – 1200 MHz)	RL	--	--	-14	dB
Equivalent Input Noise	EIN	--	--	3.9	pA/√Hz
Discrete Second-Order ⁽¹⁾	DSO	--	-63	-60	dBc
Discrete Third Order ^(1,3)	DTO	--	-73	-70	dBc

(1) Two laser test at 1310 nm/1550 nm. 40% OMI/tone. Total received optical power = 0 dBm. Distortion products measured at 40 and 200 MHz.

(2) Optical Input = 0 dBm @ 1550 nm; RF Input = 79 ch analog, OMI = 3.5%

(3) DTO may degrade to -77 dBc above 800 MHz

Outline Drawing (dimensions are in inches & mm)

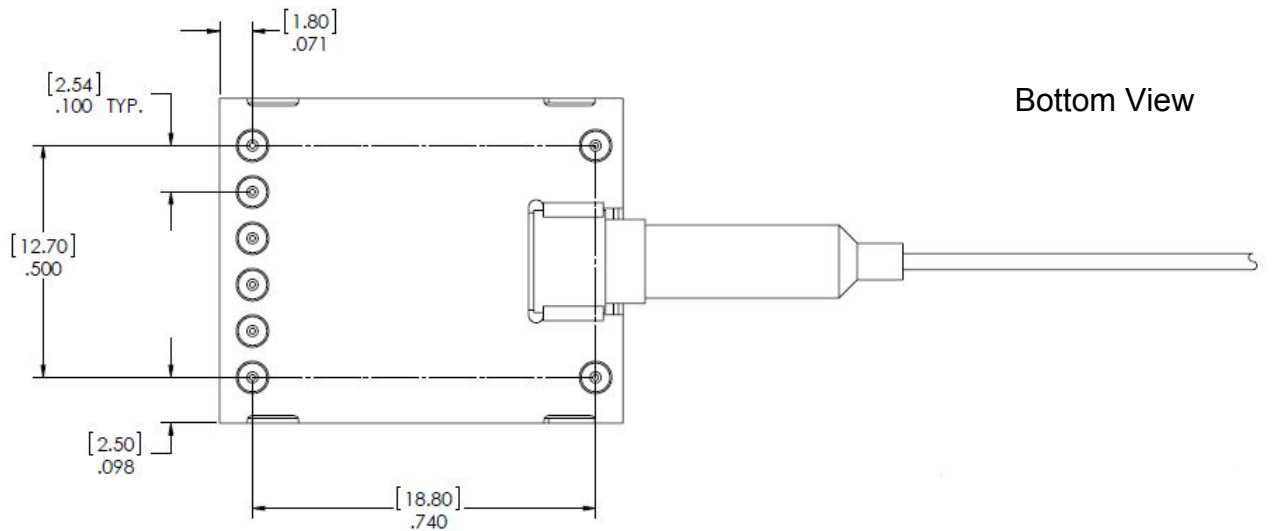
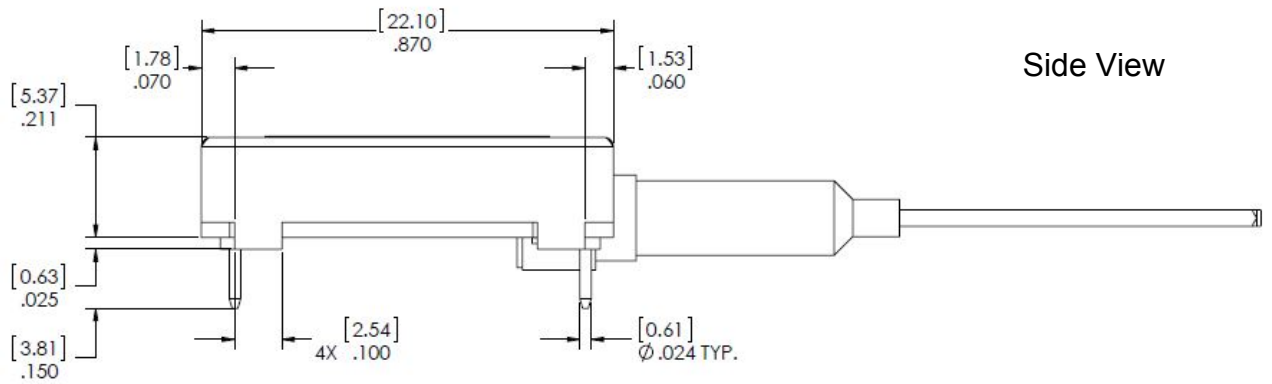
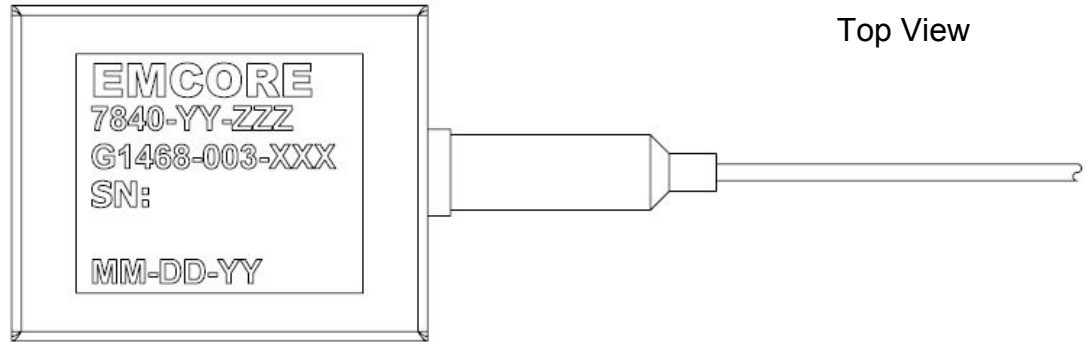

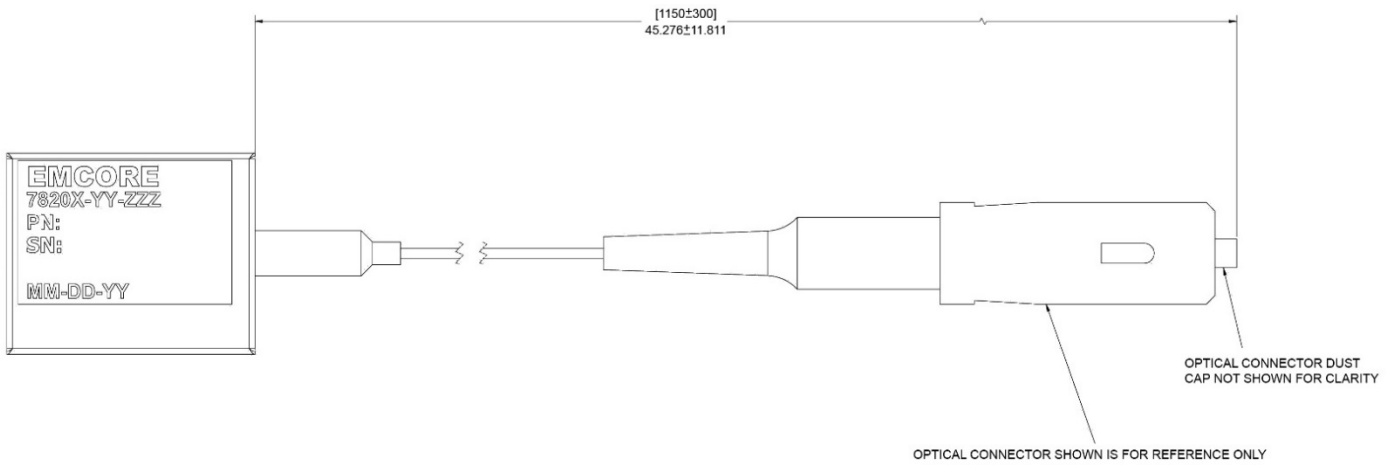
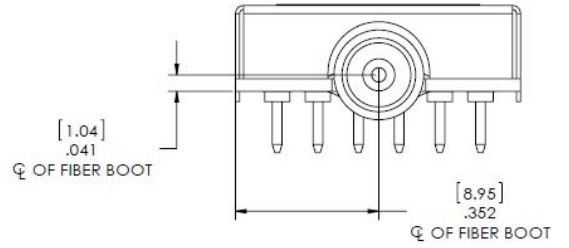
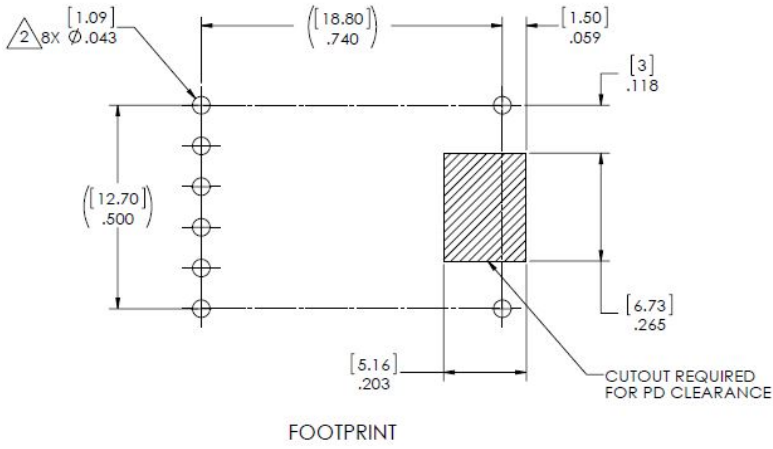

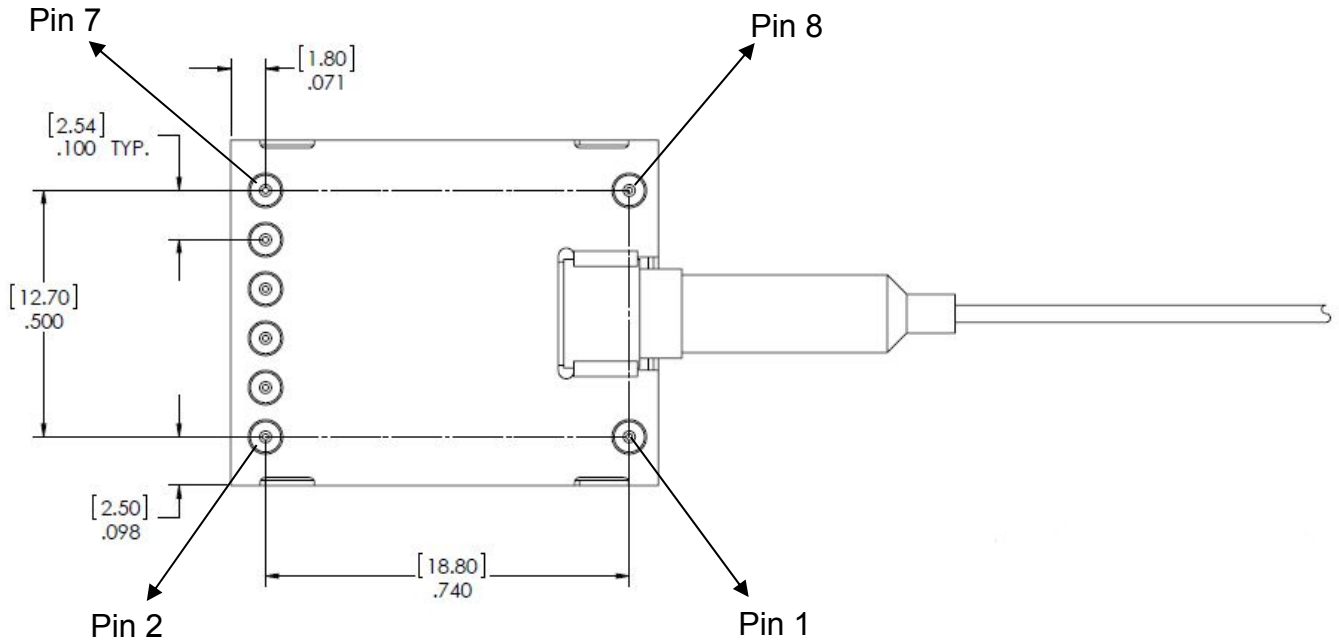

Pin Definitions

Pin	Function
1	GND
2	+5V
3	GND
4	RF OUT
5	GND
6	+12V
7	PD MONITOR
8	GND

Ordering Code Definitions

7840A-yy-zzz

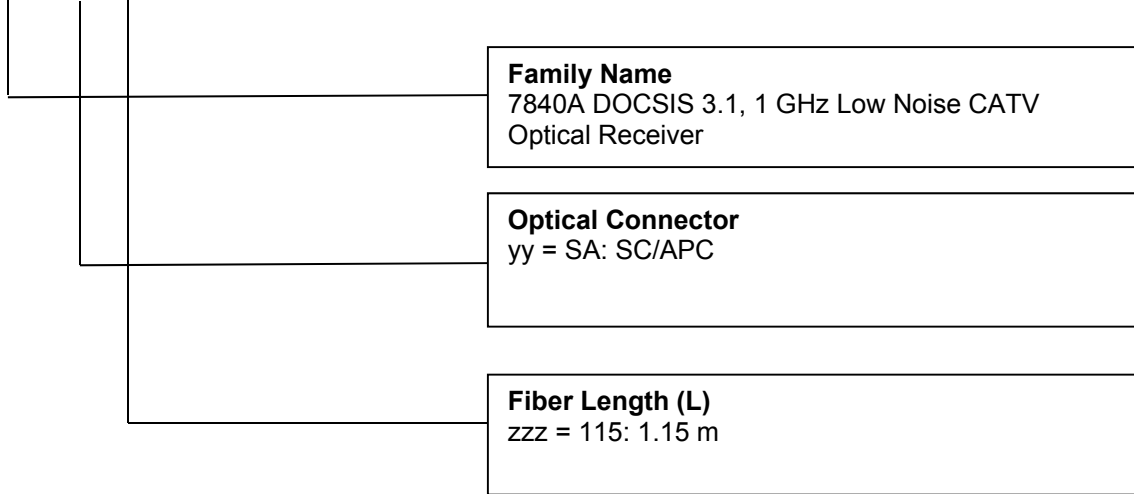

Example:

7840A-SA-115: 1 GHz Low Noise CATV Optical Receiver, SC/APC Connector, 1.15m Fiber