

5021D-B11 7 GHz, 250 ns Max Internal Fiber Delay Line System

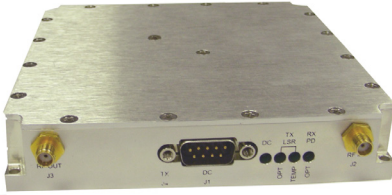

DATASHEET | NOVEMBER 2013

MICROWAVE



Applications

- Radar Testing
- Signal Processing
- Phased Array Antennas
- Phase Noise Processing

Features

- Bandwidth to 7 GHz
- High-Dynamic-Range
- -40 to +65°C
- Delays to 250 Nanoseconds
- Flat Frequency Response
- Low Phase Noise

The 5021D-B11 7 GHz fiber optic delay line delivers unmatched performance for radar testing, signal processing, phased array antennas and phase noise testing. This rugged device eliminates many of the problems that are inherent in alternative transceiver technologies.



EMCORE's fiber optic delay lines provide bandwidth that is essentially independent of fiber length, loss or delay, and triple transit signals that are immeasurable. In addition to enhanced electrical performance, the delay lines provide several mechanical advantages. EMCORE's technology takes advantage of the rigid yet flexible properties of fiber optic cable to provide repeatable enhanced phase and group delay characteristics. The small size of these components allows for a long delay in a compact package with the superior temperature stability of fiber.

Block Diagram

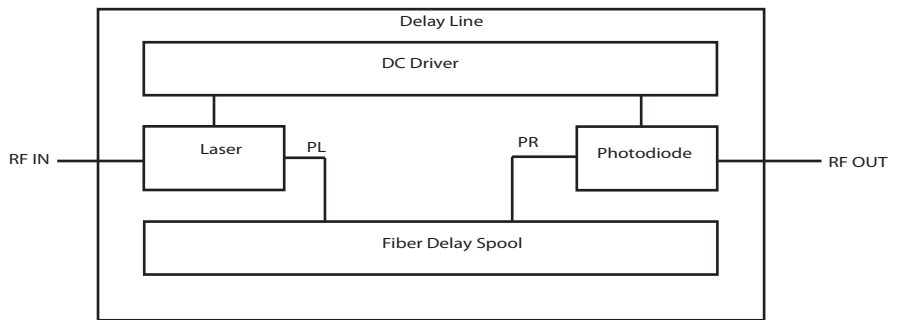

Typical S21 Graph

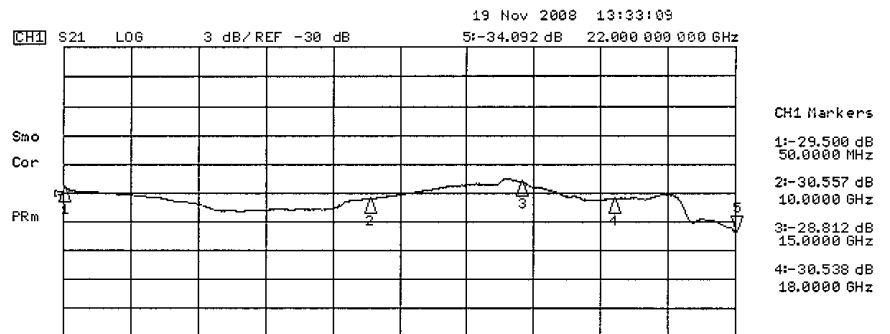

5021D-B11 7 GHz, 250 ns Max Internal Fiber Delay Line System



DATASHEET | NOVEMBER 2013

MICROWAVE

Absolute Maximum Ratings

Stresses in excess of the absolute maximum ratings can cause permanent damage to the device. These are absolute stress ratings only. Functional operation of the device is not implied at these or any other conditions in excess of those given in the operational sections of the data sheet. Exposure to absolute maximum ratings for extended periods can adversely affect device reliability.

Parameter	Min	Max	Unit
Operating Temperature Range of Baseplate	-40	+65	°C
Storage Temperature	-55	+85	°C
RF Input Power	-	20	dBm

Electrical Characteristics

Parameter	5021D-B11	Unit
Upper Band Edge Frequency	7	GHz
Lower Band Edge Frequency	0.05	GHz
Amplitude Flatness	4	dB p-p
Delay Time	250	ns, max
Insertion Loss @ 1 GHz ¹ 250 n-sec (-11 housing)	-37	dB, max
Input RF Return Loss, max 0.05 GHz - 7 GHz	-7.0	dB
Output RF Return Loss, max 0.05 GHz - 7 GHz	-9.0	dB
Impedance	50	Ohm
Input 1 dB Compression, min	+20	dBm
Input Third Order Intercept, min 0.5 GHz - 3 GHz	+30	dBm
3 GHz - 7 GHz	+25	dBm
Noise Figure 0.05 GHz - 3 GHz	44	dB
3 GHz - 7 GHz	50	dB

1. Shorter delay times will have lower loss.

DC Interface Characteristics

Pin Number	Min	Typ	Max	Max Ripple	Current
1	14 V	15 V	16 V	100 mV p-p	0.3 A max
2	4.5 V	5 V	5.5 V	200 mV p-p	1.6 A max

5021D-B11 7 GHz, 250 ns Max Internal Fiber Delay Line System

Outline Drawing

Option 11 (1" / 25.4 mm Delay System)

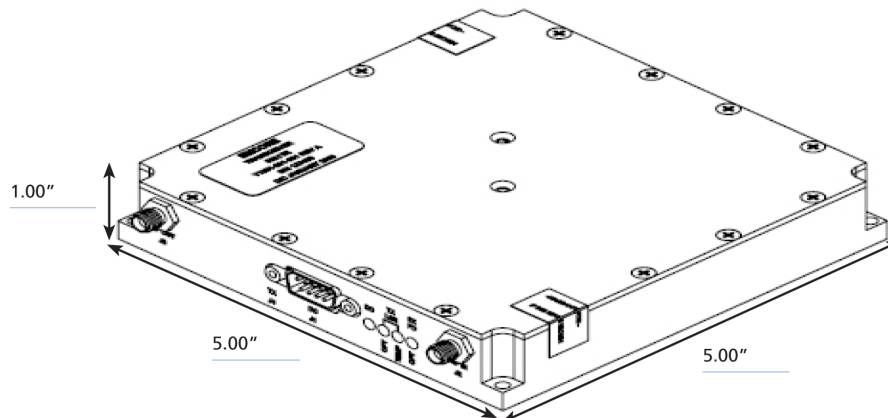

Pin/Package Information

Nine-Pin, Male D-Sub Connector

Pin Number	Function
1	+15 VDC
2	+5 VDC
3	Not Used
4	Ground
5	Ground
6	Photodiode Current Monitor
7	Alarm Common
8	Laser Current Monitor
9	Alarm

Front Panel LEDs

- Power On
- Laser Temperature Stable
- Laser Optical Power Stable
- Photodiode Optical Input Power

DC Monitor Voltages

- Photodiode Current, Pin 6:
1 V/1 mA (into 1 MOhm load). Proportional to Photodiode Optical Input Power
- Laser dc Current, Pin 8:
1 V/100 mA (into 1 MOhm load)

Alarm Circuits

- Summary Alarm, Pins 7 & 9:
Closed when unit is OK. Open if fault or no DC power.

The alarm is a dry, form A contact. The alarm is a summary of :

1. +5 VDC Regulator
2. Laser Temperature
3. Laser Optical Output Power
4. Photodiode Optical Power Input

5021D-B11 7 GHz, 250 ns Max Internal Fiber Delay Line System



DATASHEET | NOVEMBER 2013

MICROWAVE

Order Information

Model Number	Description
5021D-B11-XXXXXX	Delay Line, 7 GHz, SMA, Delay Time to 250 ns

Note1: XXXXXX designates required delay time.

Example: 5021D-B11-000250 is a 7 GHz system with 250 ns delay

Laser Safety

This product meets the appropriate standard in Title 21 of the Code of Federal Regulations (CFR). FDA/CDRH Class 1M laser product. This device has been classified with the FDA/CDRH under accession number 0220191. All versions of this laser are Class 1M laser product, tested according to IEC 60825-1:2007 / EN 60825-1:2007. An additional warning for Class 1M laser products. For diverging beams, this warning shall state that viewing the laser output with certain optical instruments (for example: eye loupes, magnifiers, and microscopes) within a distance of 100 mm may pose an eye hazard. For collimated beams, this warning shall state that viewing the laser output with certain instruments designed for use at a distance (for example: telescopes and binoculars) may pose an eye hazard.

Wavelength = 1.3/1.5 μm .

Maximum power = 30 mW.

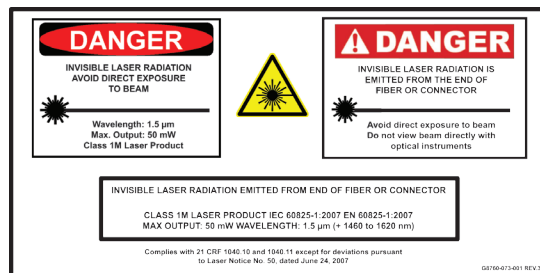

*Caution - Use of controls or adjustments or performance of procedures other than those specified herein may result in hazardous radiation exposure.

*IEC is a registered trademark of the International Electrotechnical Commission.

