

## Applications

- 1310 nm Forward Path/Return Path
- Broadcast and Narrowcast Networks
- Long Distances
- High Optical Splits

## Features

- OC-48 Pinout Compatible
- Telcordia® Technologies 468 Compliant
- 79 Channel Count
- Up to 31 mW
- Wide Temperature Range – Stable even in Harsh Environments

The 1612A/B 1310 nm forward path DFB laser modules are designed for both broadcast and narrowcast analog applications. The highly linear OC-48 pinout compatible devices feature options up to 31mW of minimum optical output power with superior distortion performance over an enhanced temperature range of 40°C to +85°C.

## Performance Highlights

Parameter	Min	Typical	Max	Units
Wavelength	1300	-	1320	nm
Optical Output Power (multiple versions)	4-31	-	-	mW
Temperature Range	-40	-	+85	°C
Frequency Range	5	-	1002	MHz
Carrier to Noise Ratio	51	-	-	dB
Composite Second Order (multiple versions)	55-60	-	-	dB
Composite Triple Beat	65	-	-	dB



## Absolute Maximum Ratings

Stresses in excess of the absolute maximum ratings can cause permanent damage to the device. These are absolute stress ratings only. Functional operation of the device is not implied at these or any other conditions in excess of those given in the operational sections of the data sheet. Exposure to absolute maximum ratings for extended periods can adversely affect device reliability.

Parameter	Symbol	Condition	Min	Max	Unit
Operating Temperature Range	$T_C$	Continuous	-40	+85	°C
Storage Temperature Range	$T_{STG}$	-	-40	+85	°C
Laser Forward dc Current	-	-	-	150	mA
Photodiode Reverse Voltage	$V_{RPD}$	-	-	10	V
Laser Reverse Voltage, dc	-	-	-	1	V
ESD	-	HBM: R = 1500 Ohm, C = 100pF	-500	500	V
TEC Current	$I_{TEC}$	Continuous	-1.9	1.9	A

## Electrical/Optical Characteristics

Laser Temperature (TL) = 25°C,  $I_F = I_{OP}$ , Beginning of Life (BOL)

Parameter	Symbol	Condition	Min	Typ	Max	Unit
Wavelength	-	-	1300	-	1320	nm
Optical Output Power	-	1612-xxxx-04 version See ordering page for options 1612-xxxx-31 version	4 31	-	-	mW mW
Optical Isolation	ISO	-	30	-	-	dB
Optical Return Loss	ORL	$T_C$	40	-	-	dB
Sidemode Suppression Ratio	SMSR	-	35	-	-	dB
Threshold Current	$I_{TH}$	-	-	-	20	mA
Operating Current	$I_{OP}$	varies with power option	-	-	120	mA
Monitor PD Responsivity	$r_{PD}$	$V_{RM} = 5V$	10	-	200	$\mu A/mW$
Thermistor Resistance	$R_{TH}$	$T_{OP} = 25^\circ C$	9.5	10	10.5	KOhm
Thermistor Temp. Coefficient	$TC_{TH}$	$T_{OP} = 25^\circ C$	-	-4.4	-	%/°C
TEC Current	$I_{TEC}$	$-40 < T_C < +85^\circ C$ , $I_F = 100$ mA	-1.5	-	1.6	A
Fiber Length	-	May include splice	1.0	1.5	-	m
Fiber Buffer	-	-	-	900	-	$\mu m$
Fiber Core / Cladding	-	-	-	9/125	-	$\mu m$

## RF Characteristic

Parameter	Symbol	Condition	Min	Typ	Max	Unit
Frequency Range	F	-	5	-	1002	MHz
Frequency Response	S21	$I_F = 60 \text{ mA}$ , 5 MHz-1002 MHz	-	-	$\pm 0.75$	dB
Carrier-to-Noise Ratio	CNR	-	51	-	-	dB
Comp. Second Order, 1612A	CSO	4, 6, 8 mW options $\geq 10 \text{ mW}$ options	55 57	- -	- -	dB dB
Comp. Second Order, 1612B	CSO	-	60	-	-	dB
Composite Triple Beat, 1612A/B	CTB	-	65	-	-	dB
Relative Intensity Noise	RIN	-	-	<-155	-	dB/Hz

OMI = 3.7% for 79ch NTSC

In order to prevent reflection-induced distortion, the laser must be connected to an optical cable having a return loss of at least 55 dB for discrete reflections and 30 dB for distributed reflections.

## Outline Drawing (dimensions are in inches & mm)

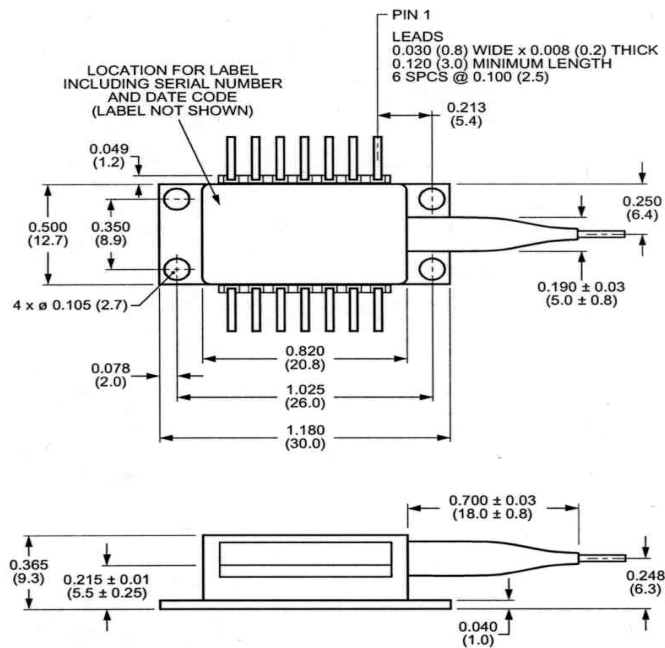

**Electrical Schematics**

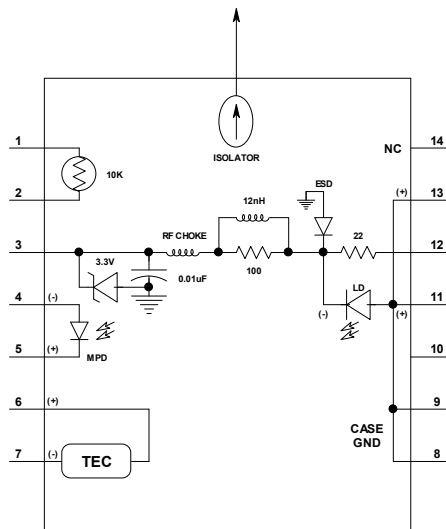

Figure 1. 1612A/B Laser Schematic

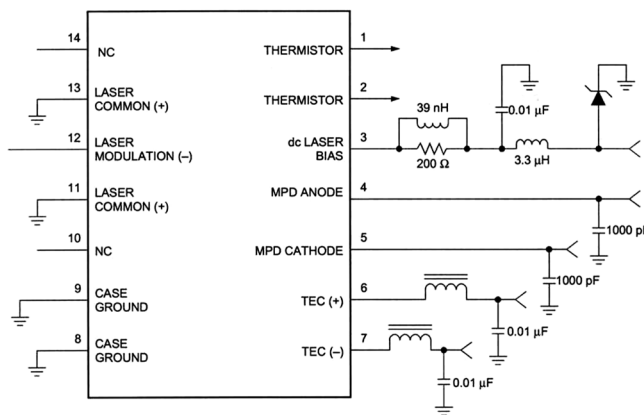

Figure 2. 1612A/B Circuit Schematic

**Pin Definitions**

Pin	Description
1	Thermistor
2	Thermistor
3	Dc Laser Bias (-)
4	MPD Anode (-)
5	MPD Cathode (+)
6	Thermal Electric Cooler (+)
7	Thermal Electric Cooler (-)
8	Case Ground
9	Case Ground
10	NC
11	Laser Common (+)
12	Laser Modulation (-)
13	Laser Common (+)

**Ordering Code Definitions**

1612x – www – yy – zz

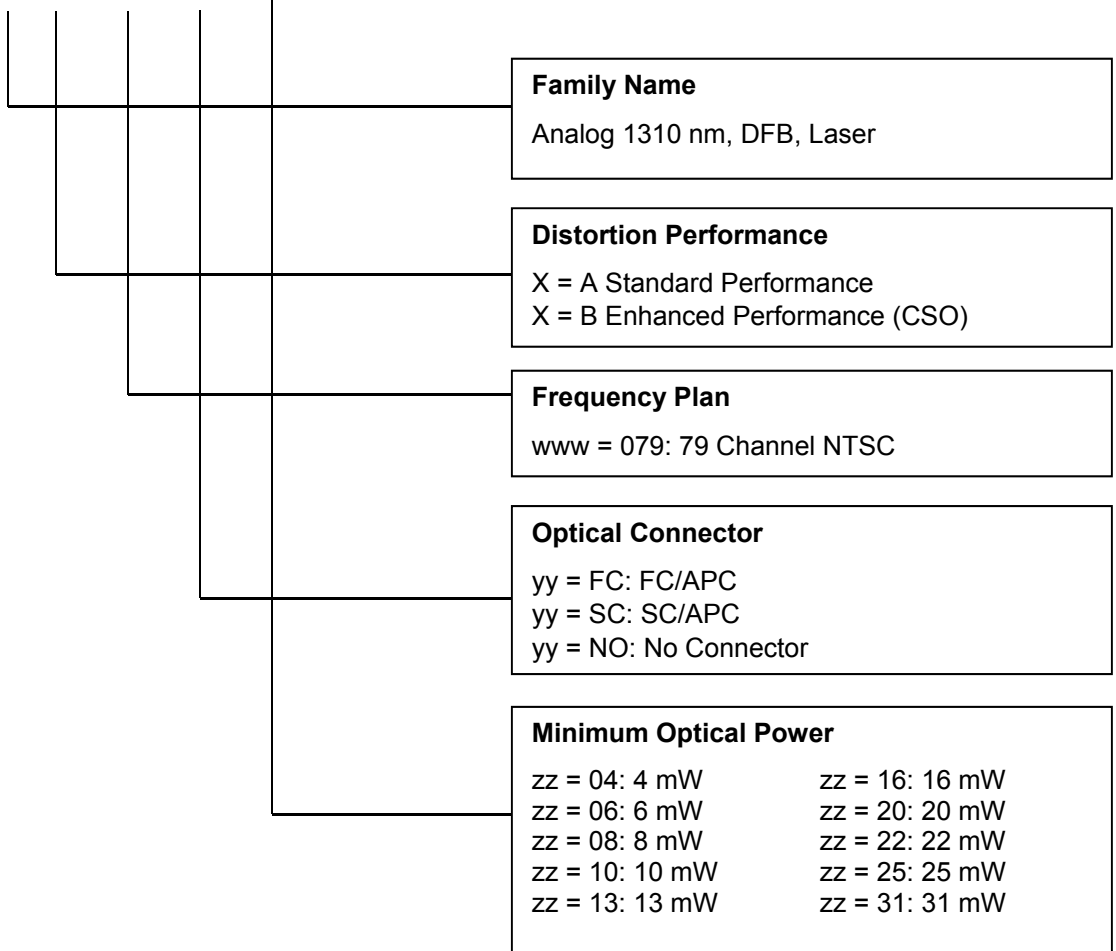

**Example**

**1612A-079-SC-10:** DFB 1310 nm, Standard Performance, 79 Channel NTSC, SC/APC Connector, 10mW

## Laser Safety

This product meets the appropriate standard in Title 21 of the Code of Federal Regulations (CFR). FDA/CDRH Class 1 laser product. This device has been classified with the FDA/CDRH under accession number 0220191.

All Versions of this laser are Class 1 laser product, tested according to IEC 60825-1:2014/EN 60825-1:2014

Single-mode fiber pigtail with SC/APC connectors (standard).

Wavelength = 1.3  $\mu\text{m}$ .

Maximum power = 50 mW.

Because of size constraints, laser safety labeling (including an FDA class 1 label) is not affixed to the module, but attached to the outside of the shipping carton.

Product is not shipped with power supply.

**Caution: Use of controls, adjustments and procedures other than those specified herein may result in hazardous laser radiation exposure.**

