

## Applications

- 1310 nm Transmission
- Wireless/DAS Applications
- Long Distances
- High Optical Splits

## Features

- OC-48 Pinout Compatible
- *Telecordia Technologies™* 468 Compliant
- Industrial Temperature Range – Stable Even in Harsh Environments

The 1615A 1310 nm DFB laser modules are designed for both wireless and distributed antenna system applications. This highly-linear OC-48 pinout compatible device delivers superior distortion performance over an enhanced temperature range of -40°C to +85°C.

## Performance Highlights

Parameter	Min	Typical	Max	Units
Wavelength	1300	-	1320	nm
Slope Efficiency	0.30	-	-	mW/mA
Temperature Range	-40	-	+85	°C
Frequency Range	5	-	2700	MHz
2 <sup>nd</sup> Order IMD	62	-	-	dB
3 <sup>rd</sup> Order IMD	70	-	-	dB

## Absolute Maximum Ratings

Stresses in excess of the absolute maximum ratings can cause permanent damage to the device. These are absolute stress ratings only. Functional operation of the device is not implied at these or any other conditions in excess of those given in the operational sections of the data sheet. Exposure to absolute maximum ratings for extended periods can adversely affect device reliability.

Parameter	Symb	Condition	Min	Max	Unit
Operating Temperature Range	T <sub>C</sub>	Continuous	-40	+85	°C
Storage Temperature Range	T <sub>STG</sub>	-	-40	+85	°C
Laser Forward dc Current	-	-	-	150	mA
Photodiode Reverse Voltage	V <sub>RPD</sub>	-	-	10	V
Laser Reverse Voltage, dc	-	-	-	1	V
ESD	-	HBM: R = 1500 Ohm, C = 100pF	-500	500	V
TEC Current	I <sub>TEC</sub>	Continuous	-1.9	1.9	A



## Electrical/Optical Characteristics

Laser Temperature (TL) = 25°C, I<sub>F</sub> = I<sub>OP</sub>, Beginning of Life (BOL)

Parameter	Symbol	Condition	Min	Typ	Max	Unit
Wavelength	-	-	1300	-	1320	nm
Slope Efficiency	n	I <sub>op</sub> =I <sub>th</sub> +40mA	0.3	-	-	mW/mA
Optical Isolation	ISO	-	30	-	-	dB
Optical Return Loss	ORL	T <sub>c</sub>	40	-	-	dB
Side Mode Suppression Ratio	SMSR	-	35	-	-	dB
Threshold Current	I <sub>TH</sub>	-	-	-	20	mA
Operating Current	I <sub>OP</sub>	-	-	-	120	mA
Monitor PD Responsivity	r <sub>PD</sub>	V <sub>RM</sub> =5V	10	-	200	μA/mW
Thermistor Resistance	R <sub>TH</sub>	T <sub>OP</sub> = 25 °C	9.5	10	10.5	KOhm
Thermistor Temp. Coefficient	TC <sub>TH</sub>	T <sub>OP</sub> = 25 °C	-	-4.4	-	%/°C
TEC Current	I <sub>TEC</sub>	-40<T <sub>C</sub> <+85°C, I <sub>F</sub> = 100 mA	-1.5	-	1.6	A
Fiber Length	-	-	1.0	1.5	-	m
Fiber Buffer	-	-	-	900	-	μm
Fiber Core / Cladding	-	-	-	9/125	-	μm

## RF Characteristic

Parameter	Symbol	Condition	Min	Typ	Max	Unit
Frequency Range	F	-	5	-	2700	MHz
Frequency Response	S21	5 MHz to 2700 MHz I <sub>F</sub> = I <sub>th</sub> +40mA mA, T <sub>OP</sub> = 25°C	-	-	±2	dB
2 <sup>nd</sup> Order IMD	IMD2	900 MHz (f1 = 942 MHz, f2 = 943 MHz) OMI = 5% per carrier <sup>(i)</sup>	-	-	-62	dBc
		1800 MHz (f1 = 943 MHz, f2 = 1885 MHz) OMI = 5% per carrier <sup>(i)</sup>	-	-	-64	dBc
3 <sup>rd</sup> Order IMD	IMD3	900 MHz (f1 = 942 MHz, f2 = 943 MHz) OMI = 5% per carrier <sup>(i)</sup>	-	-	-80	dBc
		1800 MHz (f1 = 1842 MHz, f2 = 1843 MHz) OMI = 5% per carrier <sup>(i)</sup>	-	-	-78	dBc
		2100 MHz (f1 = 2140 MHz, f2 = 2145 MHz) OMI = 5% per carrier <sup>(i)</sup>	-	-	-72	dBc
		2600 MHz (f1 = 2640 MHz, f2 = 2650 MHz) OMI = 5% per carrier <sup>(i)</sup>	-	-	-70	dBc
Relative Intensity Noise	RIN	-	-	<-155	-	dB/Hz

(i) Test conditions: I<sub>op</sub> = I<sub>th</sub>+40 mA, Temp = 25°C, Fiber Length = 2 km

In order to prevent reflection-induced distortion, the laser must be connected to an optical cable having a return loss of at least 55 dB for discrete reflections and 30 dB for distributed reflections.

## Outline Drawing (dimensions are in inches & mm)

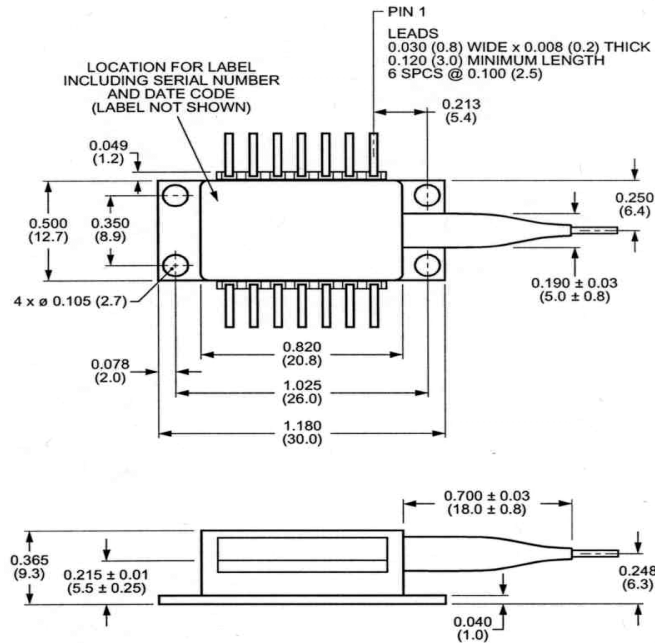

## Electrical Schematics

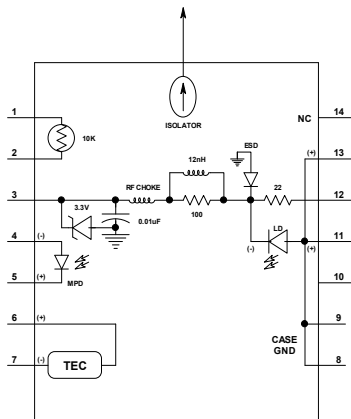

Figure 1. 1615A Laser Schematic

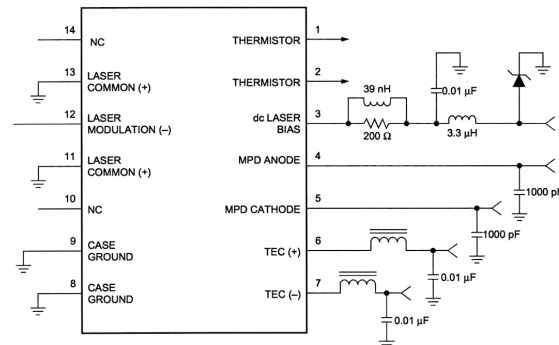

Figure 2. 1615A Circuit Schematic with suggested matching circuit

## Pin Definitions

Pin	Description
1	Thermistor
2	Thermistor
3	DC Laser Bias (-)
4	MPD Anode (-)
5	MPD Cathode (+)
6	Thermal Electric Cooler (+)
7	Thermal Electric Cooler (-)
8	Case Ground
9	Case Ground
10	NC
11	Laser Common (+)
12	Laser Modulation (-)
13	Laser Common (+)

## Ordering Information

Part Number	Descriptions
1615A-SC-20	DFB 1310 nm, SC/APC Connector

## Laser Safety

This product meets the appropriate standard in Title 21 of the Code of Federal Regulations (CFR). FDA/CDRH Class 1 laser product. This device has been classified with the FDA/CDRH under accession number 0220191.

All Versions of this laser are Class 1 laser product, tested according to IEC 60825-1:2007/EN 60825-1:2007

Single-mode fiber pigtail with SC/APC connectors (standard).

Wavelength = 1.3 μm.

Maximum power = 50 mW.

Because of size constraints, laser safety labeling (including an FDA class 1 label) is not affixed to the module, but attached to the outside of the shipping carton.

Product is not shipped with power supply.

**Caution: Use of controls, adjustments and procedures other than those specified herein may result in hazardous laser radiation exposure.**

